

**BUILDING WISE FSI STATEMENT**

BUILDING	NO OF SAME BUILDING	FSI AREA				DU	TOTAL FSI AREA
		COMM.	RESI.	IND.	SPEC.		
A-1 (BUILDING)		0.00	1013.56	0.00	0.00	8	1013.56
<b>Total</b>		0.00	1013.56	0.00	0.00	8	1013.56

**FLOOR WISE FSI STATEMENT: A (BUILDING)**

FLOORS	FSI AREA				DU	TOTAL FSI AREA
	COMM.	RESI.	IND.	SPEC.		
Terrace	0.00	0.00	0.00	0.00	0	0.00
FOURTH FLOOR	0.00	246.22	0.00	0.00	2	246.22
THIRD FLOOR	0.00	246.22	0.00	0.00	2	246.22
SECOND FLOOR	0.00	246.22	0.00	0.00	2	246.22
FIRST FLOOR	0.00	246.22	0.00	0.00	2	246.22
STILT PARKING FLOOR	0.00	28.68	0.00	0.00	0	28.68
<b>Total</b>	0.00	1013.56	0.00	0.00	8	1013.56

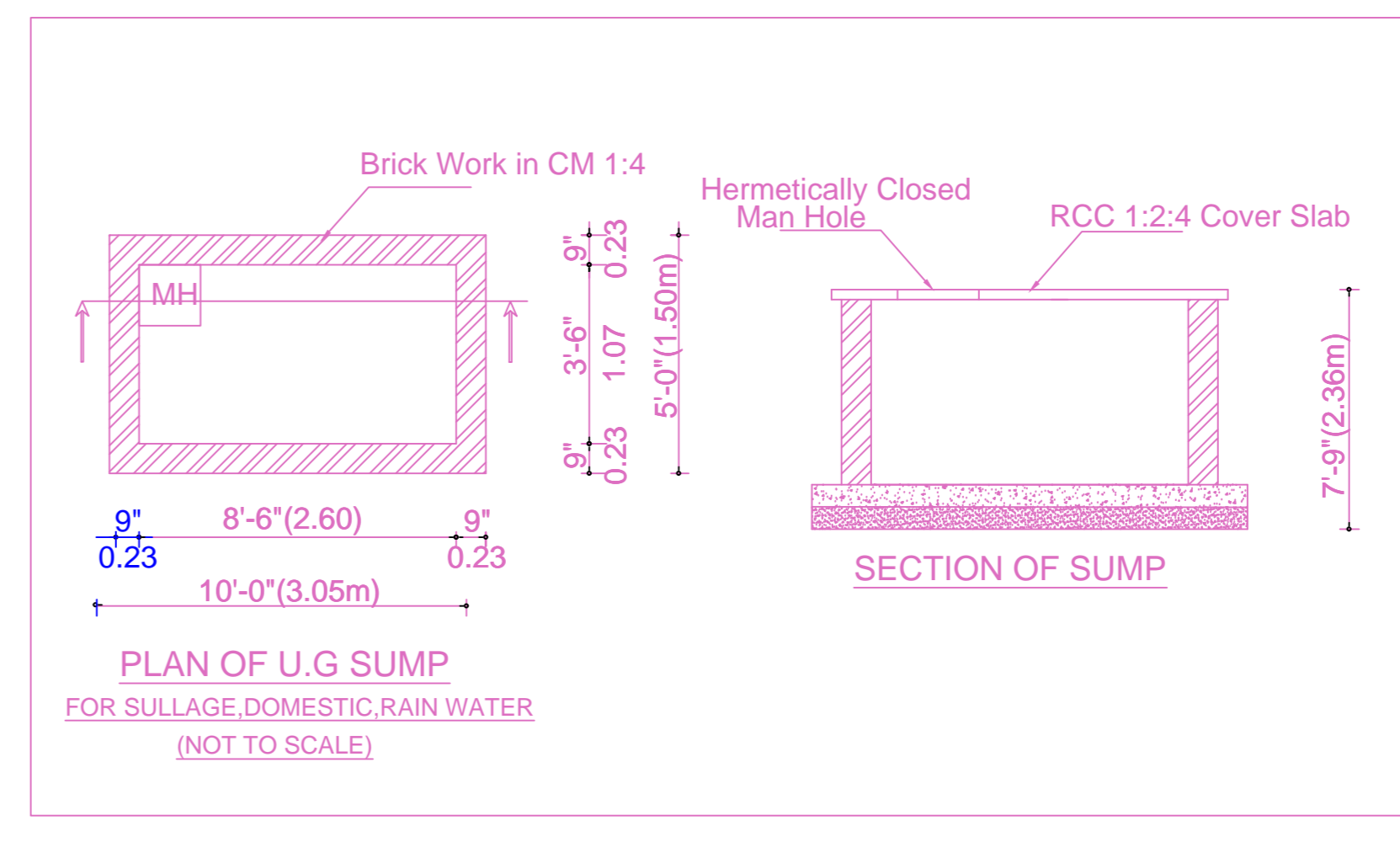
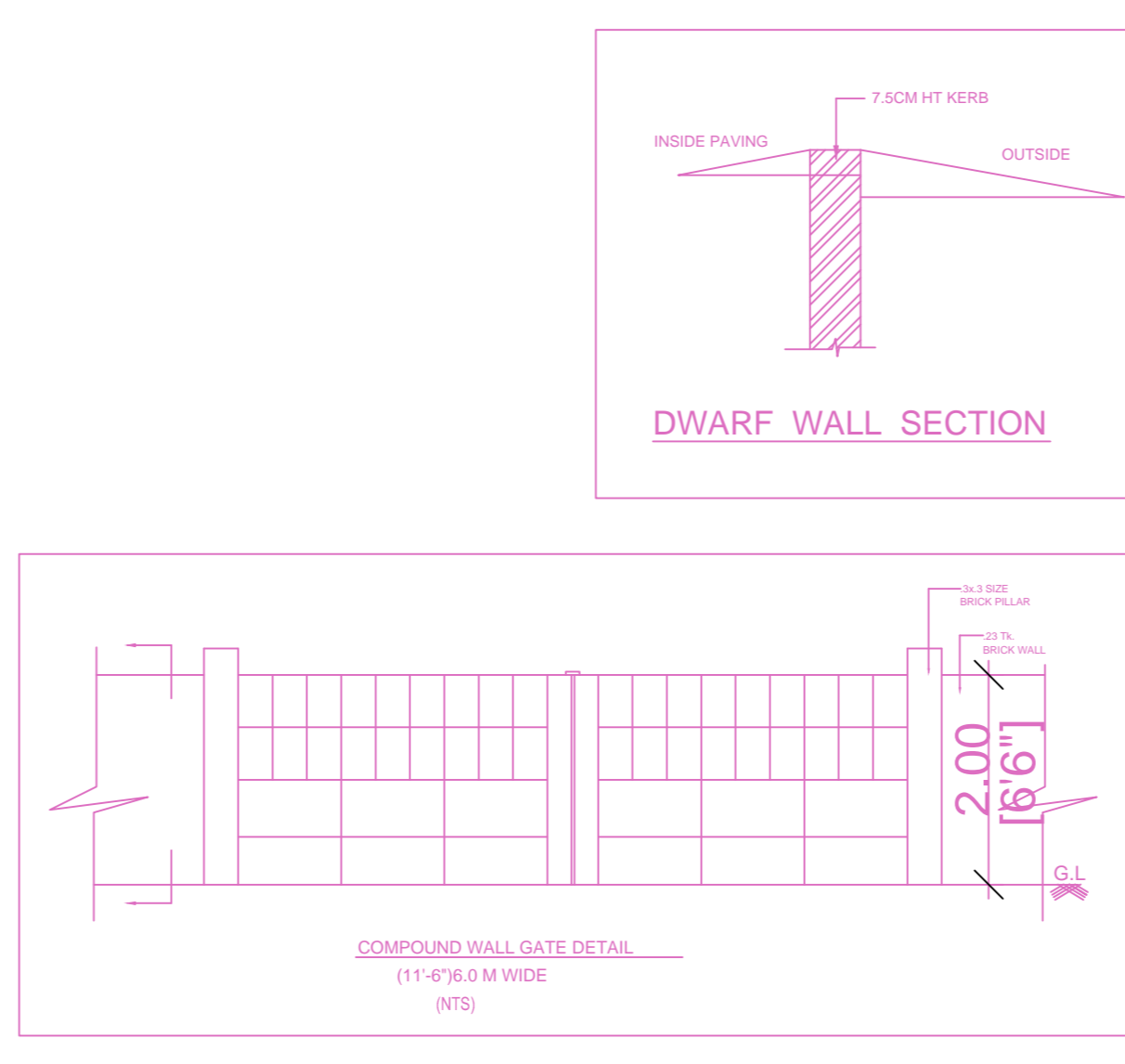

**APPROVAL CONDITION**

Scale: 1:100

**CHENNAI METROPOLITAN DEVELOPMENT AUTHORITY**

**APPROVED**

SUBJECT TO THE CONDITIONS MENTIONED IN THIS OFFICE

For (Deputy Planner / Chief Planner / Member-Secretary)  
High Rise Building / Non High Rise Building  
This Approval is valid only after building Permit is issued by the concerned Local Body.

KEY NO. 4788

QR CODE