

PLAN SHOWING THE PROPOSED CONSTRUCTION OF STILT FLOOR + 2 FLOORS + 3RD FLOOR (PART) RESIDENTIAL WITH 16 DWELLING UNITS (12.0M HEIGHT) AT PLOT NO. 8 AS PER GCC APPROVED SUBDIVISION, BALARAMAN GARDEN ROAD, MANAPAKKAM CHENNAI COMPRISED IN S.NO.32/1B10A (PT), 32/1B10B (PT) & 32/1B10C (PT) OF MANAPAKKAM VILLAGE WITHIN THE LIMIT OF GREATER CHENNAI CORPORATION).

AREA AS PER PATTA	SG.M.
AREA AS PER DOCUMENT (AS PER APPROVED SUBDIVISION)	643.44
AREA CONSIDERED FOR FSI	643.44
STREET ALIGNMENT/ROAD WIDENING/LINK ROAD	0.00
OSR AREA	0.00
TOTAL FSI AREA	1284.64
FSI FACTOR	1.997
COVERAGE AREA (PERCENTAGE %)	N.A.

A) PARKING STATEMENT		
VEHICLE	REQUIRED	PROVIDED
LORRY	0	0
CAR	11	11
TWO WHEELER	13	19
CYCLE		

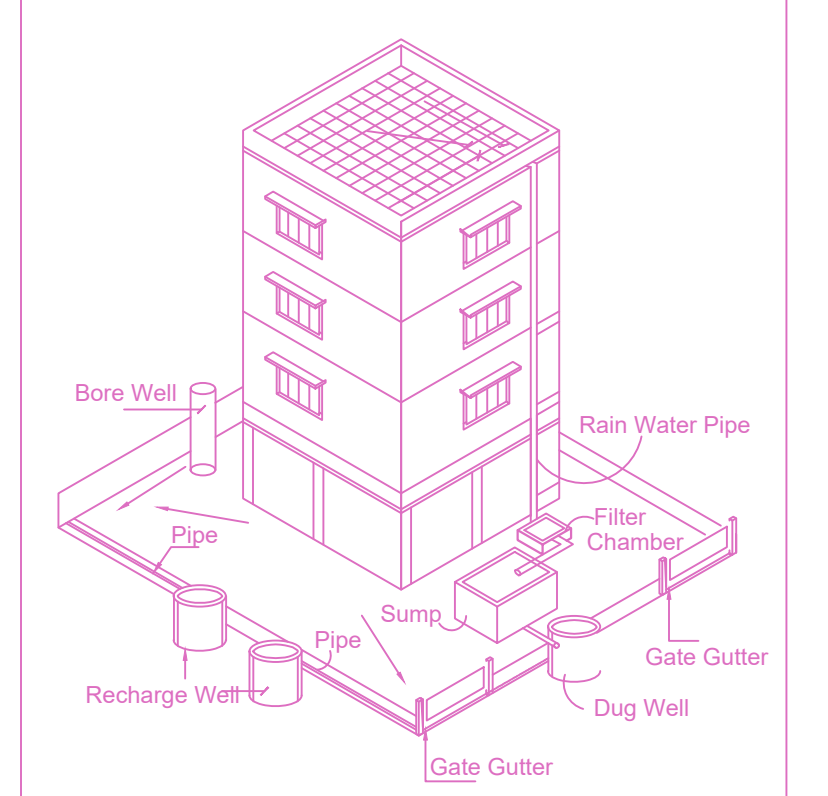
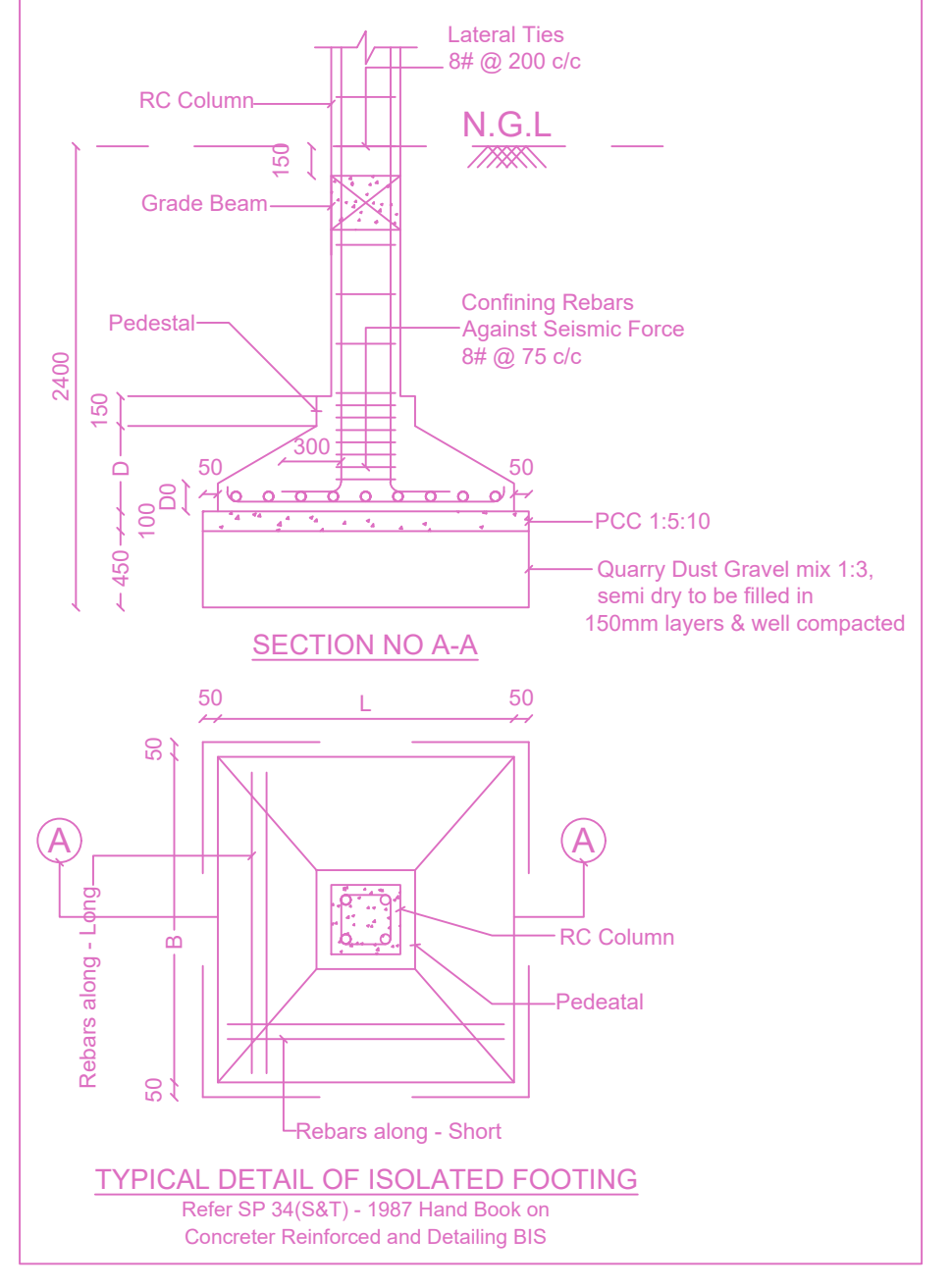
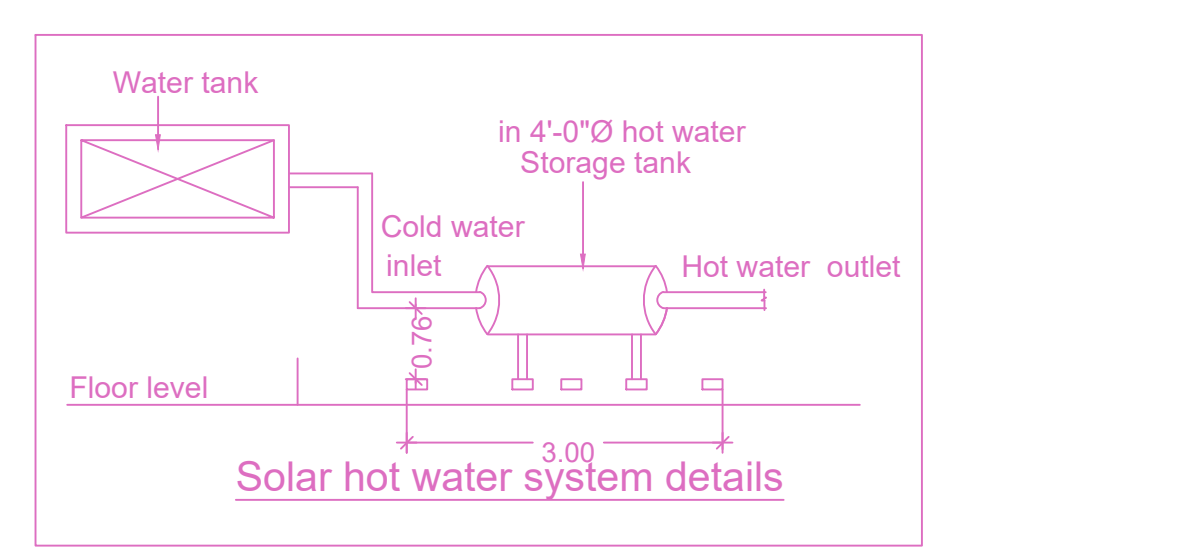
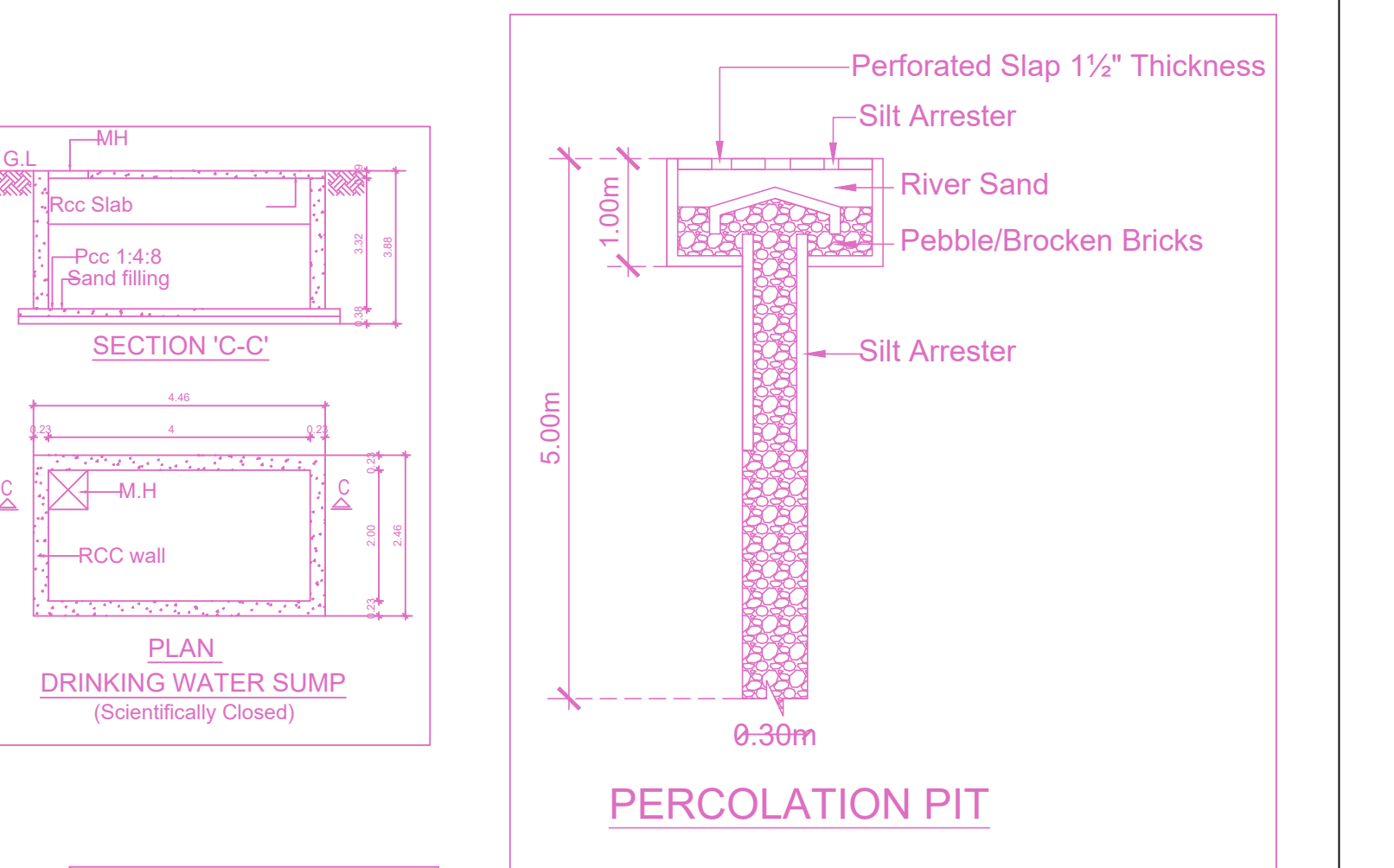
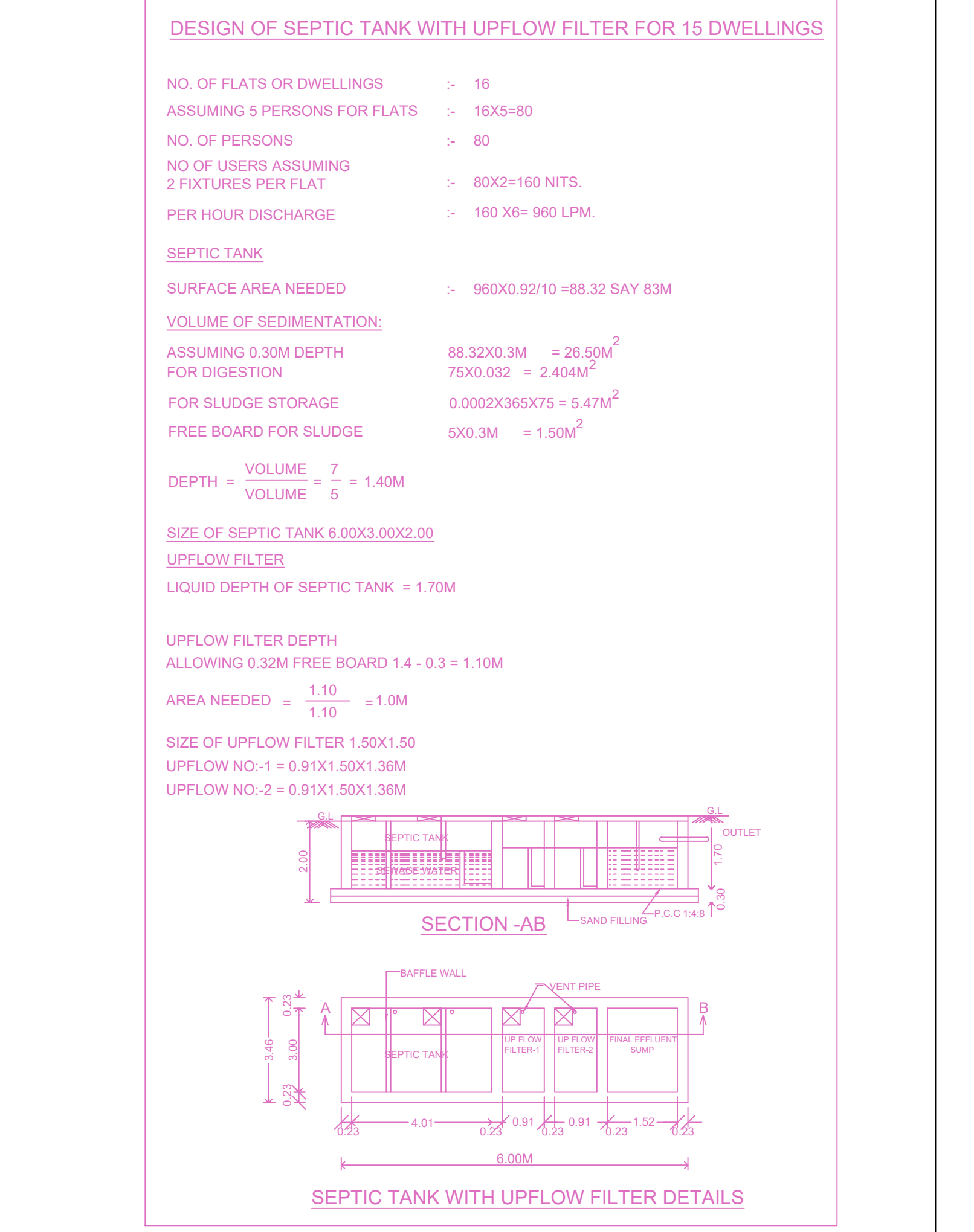

FLOOR WISE FSI STATEMENT-A (RESIDENTIAL)							
FLOORS	COMM.	RESI.	IND.	SPEC.	DU	TOTAL FSI AREA	
Terrace	0.00	0.00	0.00	0.00	0	0.00	
THIRD FLOOR	0.00	366.93	0.00	0.00	4	366.93	
SECOND FLOOR	0.00	444.45	0.00	0.00	6	444.45	
FIRST FLOOR	0.00	444.45	0.00	0.00	6	444.45	
STILT PARKING FLOOR	0.00	28.81	0.00	0.00	0	28.81	
Total	0.00	1284.64	0.00	0.00	16	1284.64	

BUILDING WISE FSI STATEMENT									
BUILDING	NO OF SAME BUILDING	FSI AREA				DU	TOTAL FSI AREA		
		COMM.	RESI.	IND.	SPEC.				
A-1 (RESIEN...)	0.00	1284.64	0.00	0.00	0.00	16	1284.64		
Total	0.00	1284.64	0.00	0.00	0.00	16	1284.64		

