

PLAN SHOWING THE PROPOSED CONSTRUCTION OF GROUND FLOOR (PART) / STILT FLOOR (PART) + 4 FLOORS (HEIGHT- 18.30M) COMMERCIAL BUILDING (GROUND FLOOR - SHOP, 1ST TO 4TH FLOOR - OFFICE) AT PLOT NO.A, TAMBARAM VELACHERY MAIN ROAD, VENGAIVASAL, CHENNAI-600 126, COMPRISED IN OLD. S.NO.75/32, AS PER PATTA S.NO.75/32A2, VENGAIVASAL VILLAGE WITHIN THE LIMITS OF ST. THOMAS MOUNT PANCHAYAT UNION.

A) AREA STATEMENT	SQM.
AREA AS PER PATTA	1885.00
AREA AS PER DOCUMENT	2144.75
AREA CONSIDERED FOR FSI	1885.00
LAND ALREADY LEFT FOR ROAD	46.45
OSR AREA	0.00
TOTAL FSI AREA	2007.91
FSI FACTOR	1.092
COVERAGE AREA (PERCENTAGE %)	NA

A) PARKING STATEMENT	REQUIRED	PROVIDED
VEHICLE		
LORRY	0	0
CAR	17	22
TWO WHEELER	65	80
CYCLE	0	0

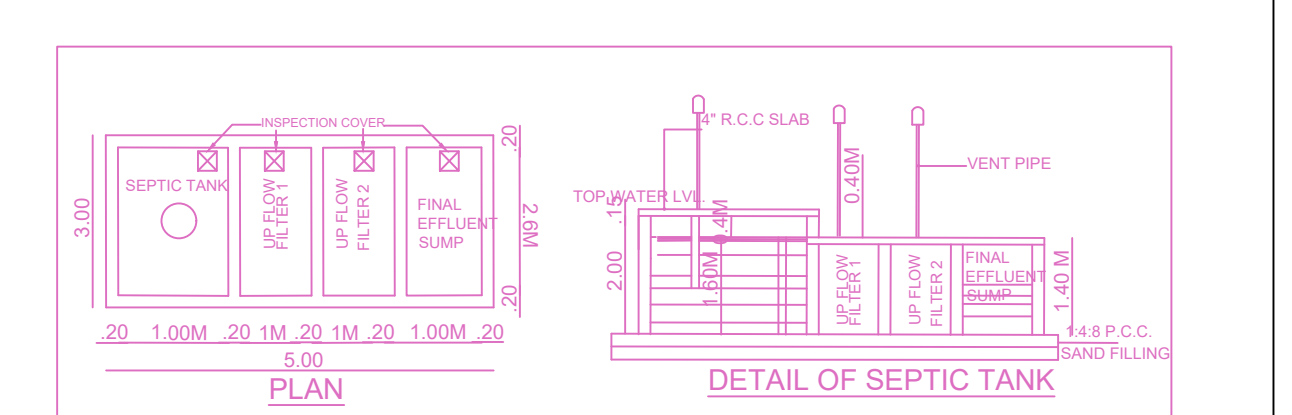
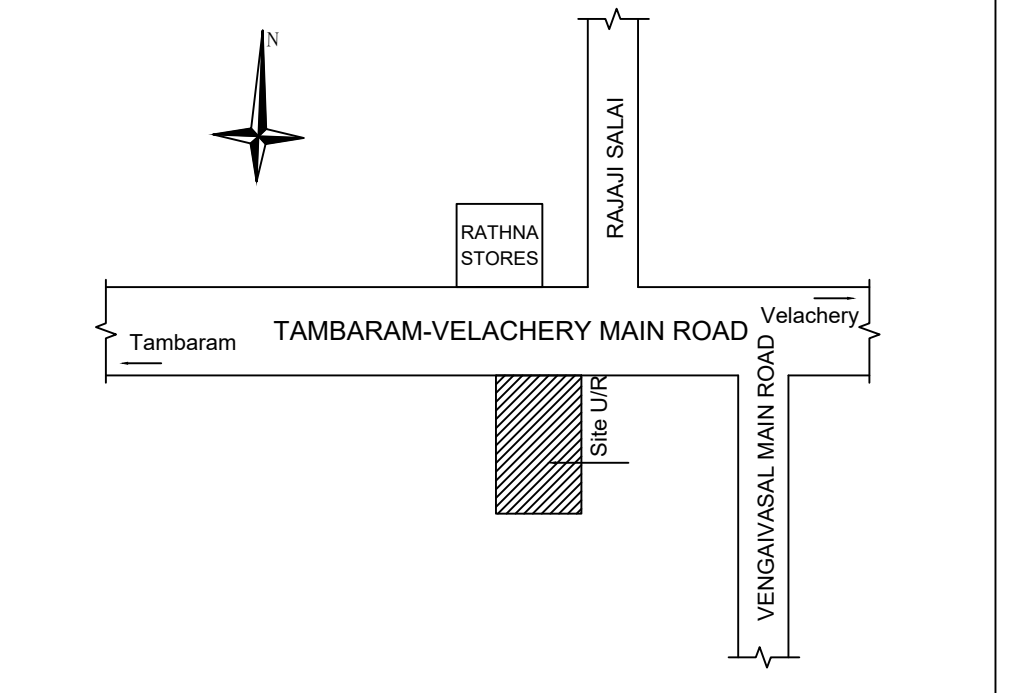

DESIGN OF SEPTIC TANK & UPFLOW FILTER

- OFFICE BUILDING - 2018.51/100 Sq.m = 20
- No OF USERS (20X5) - 100
- RATE OF WATER SUPPLY - 100LPH/DAY
- FLOW OF SEWAGE PER DAY - 100 X 100 = 10000 Litres
- DETENTION PERIOD - 20 Hrs
- TANK CAPACITY - 10000 X 2024+8333 Say 85000 litres
- THE TANK TO BE CLEANED EVERY YEAR SO SLUDGE STORAGE CAPACITY AT THE RATE OF 1SLITRES FOR PERSON PER YEAR - 100 x 15=1500 Litres
- TOTAL TANK CAPACITY - 8500+1500 = 10000 Litres
- ASSUMING SEPTIC TANK CAPACITY IS - 30 Cu.M
- DEPTH OF LIQUID IS - 2.00 M
- PLAN AREA OF THE TANK - 302+15 SQ.M
- SIZE OF THE SEPTIC TANK - 5M X 3M
- WIDTH OF THE TANK - 3M
- LENGTH OF THE TANK - 5M
- PROVIDE SEPTIC TANK SIZE - 5M X 3M X 2M
- UPFLOW FILTERS CAPACITY FOR 100 USERS - 100 X 0.045 = 4.5 Cu.M
- DEPTH - 1.45M
- HENCE MIN. AREA OF FINAL EFFLUENT SUMP - 4.5 / 1.45 = 3.10 SQ.M
- SIZE OF UPFLOW FILTER-1 - 2.60M X 1.0M X 1.45M
- SIZE OF UPFLOW FILTER-2 - 2.60M X 1.0M X 1.45M
- SIZE OF FINAL EFFLUENT SUMP - 2.60M X 1.0M X 1.45M

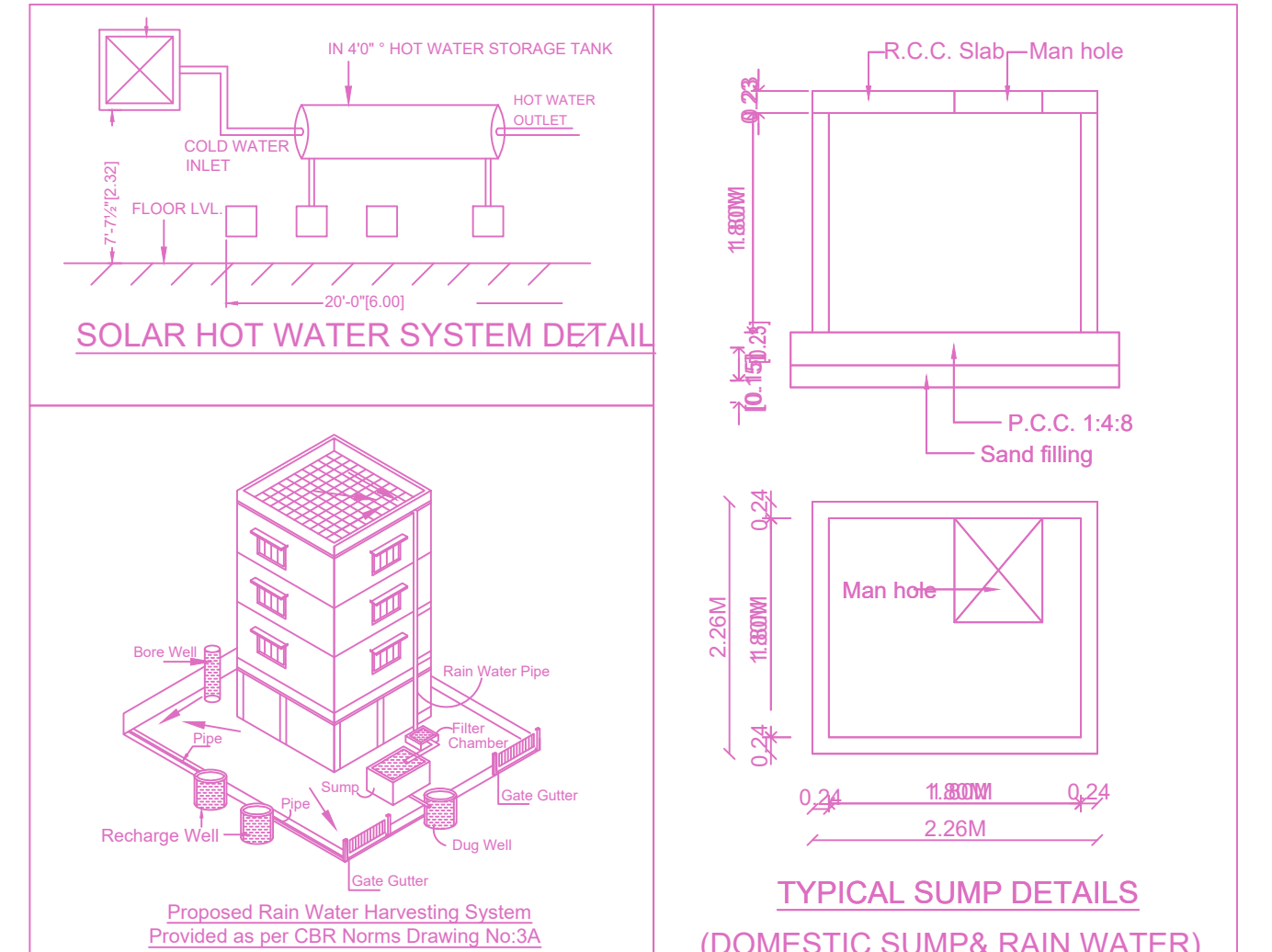
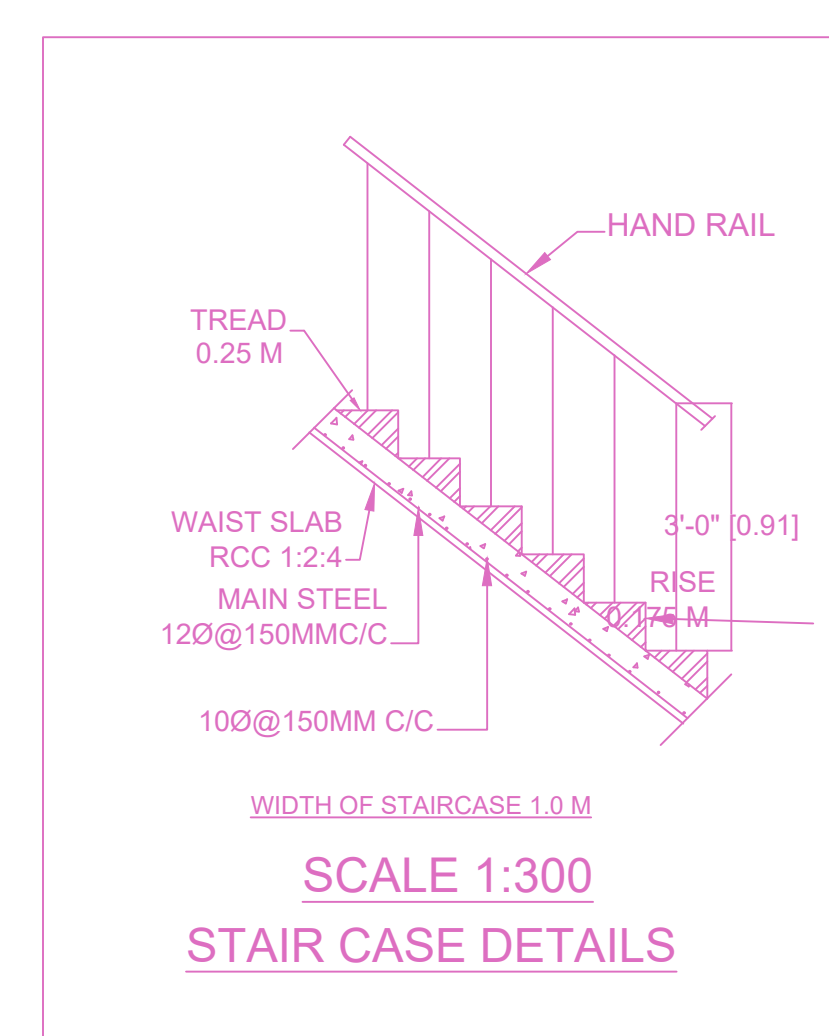
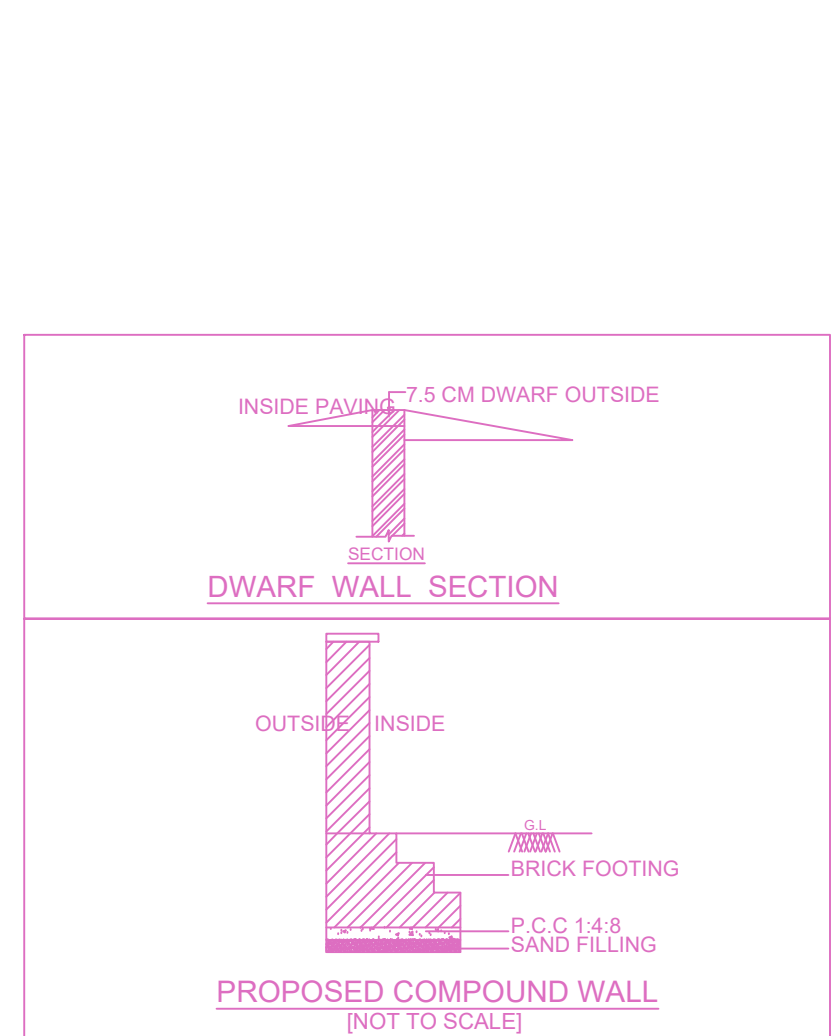
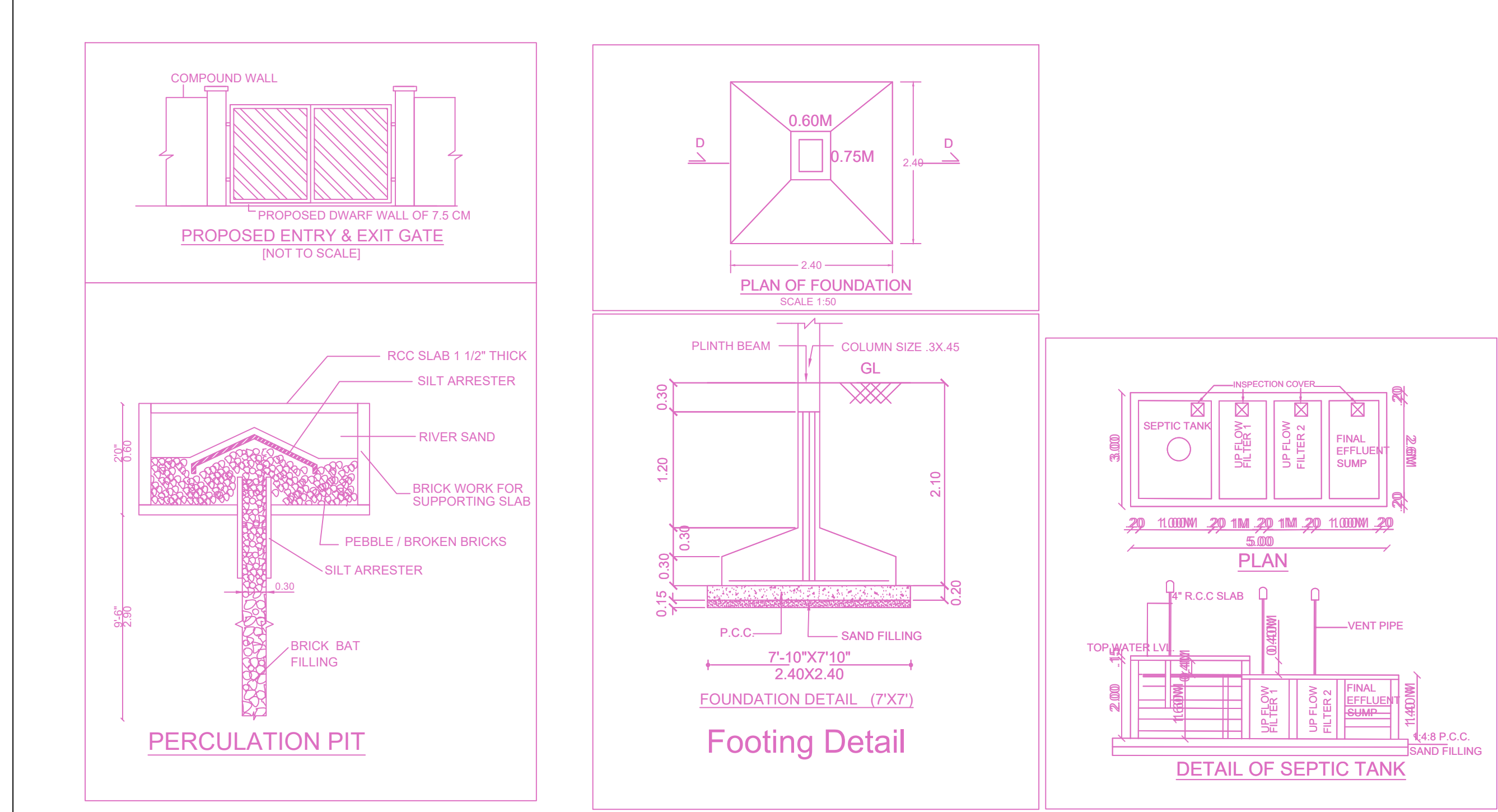

FLOOR WISE FSI STATEMENT: NHRB (COM)

FLOORS	FSI AREA				DU	TOTAL FSI AREA
	COMM.	RESI.	IND.	INST.		
STILT PARKING FLOOR	66.35	0.00	0.00	0.00	0	66.35
FIRST FLOOR	485.39	0.00	0.00	0.00	0	485.39
SECOND FLOOR	485.39	0.00	0.00	0.00	0	485.39
THIRD FLOOR	485.39	0.00	0.00	0.00	0	485.39
FOURTH FLOOR	485.39	0.00	0.00	0.00	0	485.39
Terrace	0.00	0.00	0.00	0.00	0	0.00
Total	2007.91	0.00	0.00	0.00	0	2007.91

BUILDING WISE FSI STATEMENT

BUILDING	NO OF SAME BUILDING	FSI AREA				DU	TOTAL FSI AREA
		COMM.	RESI.	IND.	INST.		
NHRB-1 (COM)	1	2007.91	0.00	0.00	0.00	0	2007.91
Total	1	2007.91	0.00	0.00	0.00	0	2007.91

APPROVAL CONDITION

SCALE 1:100

CHENNAI METROPOLITAN DEVELOPMENT AUTHORITY

APPROVED

SUBJECT TO THE CONDITIONS MENTIONED IN THIS OFFICE